



GDPR Compliant sensors with **on-board AI** and computer vision featuring an **industrial-grade** design, **easy setup**, **high accuracy** and making it ideal for smart(er) cities and industries' applications.

Key features

- ✓ GDPR compliant by design
- ✓ AI accelerator-based processing for best-in-class performance
- ✓ Single & dual sensors for wider coverage and optimized Return on Investment
- ✓ Easy to install and configure remotely via web platform
- ✓ Effective in low light conditions
- ✓ Remote firmware updates
- ✓ Data transmission via Ethernet or Cellular
- ✓ DC12V or PoE+ supply mode
- ✓ 8-PIN circular connector for local applications (streetlight control, signage...)

SPECIFICATION



Performance	Single	Dual
Technology	Edge AI camera sensor	
Use Environment	Indoor and outdoor	
AI Processor	NPU (Neural Processing Unit)	
Accuracy	99.5% ⁽¹⁾	
Camera	Single	Dual
Image Sensor	1/2.8" progressive scan CMOS	
Resolution	2MP, 1920(H)×1080(V)	
Angular Field of View	H: 105.19° V: 55.49° D: 125.08°	
Min. Illumination	Color 0.0009lux @ F1.0 (AGC ON)	
WDR (Wide Dynamic Range)	Support	
BLC (Backlight Compensation)	Support	
DNR (Digital Noise Reduction)	3D DNR	
Lens Type	Fixed (M12)	
Focal Length (Zoom Ratio)	2.8mm	
Max. Aperture Ratio	F No. 1.0	
Min. Object Distance	1m	
Electronics	Single	Dual
Power Source	DC12V (acceptable voltage range: DC9V to DC16.8V), PoE+ (IEEE802.3at)	
Max. Power Consumption	11.5W @DC12V	13W @DC12V
Average Power Consumption	10.5W @DC12V	12W @DC12V
Network	Single	Dual
Set Up	Web GUI embedded on the device	
Data Consumption ⁽²⁾	500Mb per month	1GB per month
Bluetooth	5.0	
Wi-Fi	2.4GHz	
Ethernet/PoE+	Single	Dual
Recommended Cabling	CAT6 or later	
Addressing	DHCP, Static IP for maintenance	
Distance Limit	100m	

⁽¹⁾ Accuracy is assessed based on performance under representative conditions. In very complex environments, such as those with obstructions or very low light conditions etc., this value may vary.

⁽²⁾ Data consumption is based on capturing 2 images daily to monitor the quality.

SPECIFICATION

LTE/4G (Optional)	Single	Dual
Standard	LTE-A Cat 6	
Region/Operator	EMEA/APAC (excluding Japan and CMCC)/Brazil	
Frequency Bands	LTE-FDD: B1/B3/B5/B7/B8/B20/B28/B32 ⁽³⁾ LTE-TDD: B38/B40/B41 2xCA: B1+B1/B5/B8/B20/B28; B3+B3/B5/B7/B8/B20/B28; B7+B5/B7/B8/B20/B28; B20+B32 ⁽³⁾ ; B38+B38; B40+B40; B41+B41 WCDMA: B1/B3/B5/B8	
SIM Card Format	NANO (4FF)	
Interfaces	Single	Dual
Ethernet/PoE+	Female RJ45 port	
DC12V and GPIO	8-PIN female circular port	
Antenna	Female SMA connector	
Mechanics	Single	Dual
Housing Dimensions	280mm(L)x170mm(W)x90mm(H) (without antennas)	
Camera Dimensions	74mm(H)x151mm(D)	
Weight	Approx. 2500g	Approx. 2900g
Housing Material	Aluminium	
Color	White (extra colors on demand)	
Housing Impact Protection	IK08	
Ingress Protection	IP67	
Installation	Wall mounting, Optional: Pole mounting with provided pole mount	
General	Single	Dual
Model ⁽⁴⁾	NP-1, NP-1-4G	NP-2, NP-2-4G
Operating Conditions	-20°C to 60°C, less than 95% RH	
Included Accessories	PoE+/Ethernet IP67 connector, Allen key, DC12V power cable	
Optional Accessories	AC230V to DC12V voltage converter, Antennas, Pole mount including hose clamps, Battery, Relay/Optocoupler	
Services	Single	Dual
Warranty	1 year, extendable on demand	
Remote Technical Support ⁽⁵⁾	Yes	
Integrator Platform	Yes	
Dashboard	Optional – on demand	
SIM Card	Optional – on demand	

⁽³⁾ LTE-FDD B32 support receiving only, and is only for secondary component carrier in 2xCA.

⁽⁴⁾ Details can be found in the “MODEL NAMING CONVENTION” chapter.

⁽⁵⁾ Remote technical support by default includes assistance with installation and maintenance of detection quality.

NETWORK SERVICES AND PORT

To ensure the proper operation of the camera sensor, this section outlines the external services the device accesses and the ports it exposes. This information is essential for configuring network access and ensuring the device's compatibility with external networks.

External Services Called by the Device

Domains/IP addresses	Ports	Description
.vziosense.ai	443, 80	VizioSense services, required for device management and data exchange.
.vziosense.com	-	Additional VizioSense services and resources.
ports.ubuntu.com	-	Ubuntu package and update repositories.
.docker.io	-	Docker image registry.
.docker.com	-	Docker website and services.
.rport.io	443	Remote management and monitoring services by Rport.
.openrport.io	443	Remote management and monitoring services by OpenRport.
www.amazontrust.com	443	Amazon Trust Services, including certificate authority services.
.amazonaws.com	443, 1194, 8443, 80, 8883	Amazon Web Services (AWS) for cloud storage, compute, and IoT services.
.cloudfront.net	443	Amazon CloudFront content delivery network (CDN) for distributing content.
objects.githubusercontent.com	443	GitHub-hosted content access.
.github.com	443	GitHub website and API access.
.canonical.com	123, 80	Canonical services for updates and time synchronization.
time.cloudflare.com	123	Cloudflare NTP service for time synchronization.
ntp.ubuntu.com	123	Ubuntu NTP server for time synchronization.
.pool.ntp.org	123	NTP pool servers for time synchronization.
8.8.8.8	53	Google's public DNS service.
8.8.4.4	53	Secondary Google's public DNS service.

Ports Exposed by the Device

Port	Description
22	SSH - secure shell for remote debugging and maintenance.
8080	HTTP Alternative - used for local web UI access.

INTERFACES

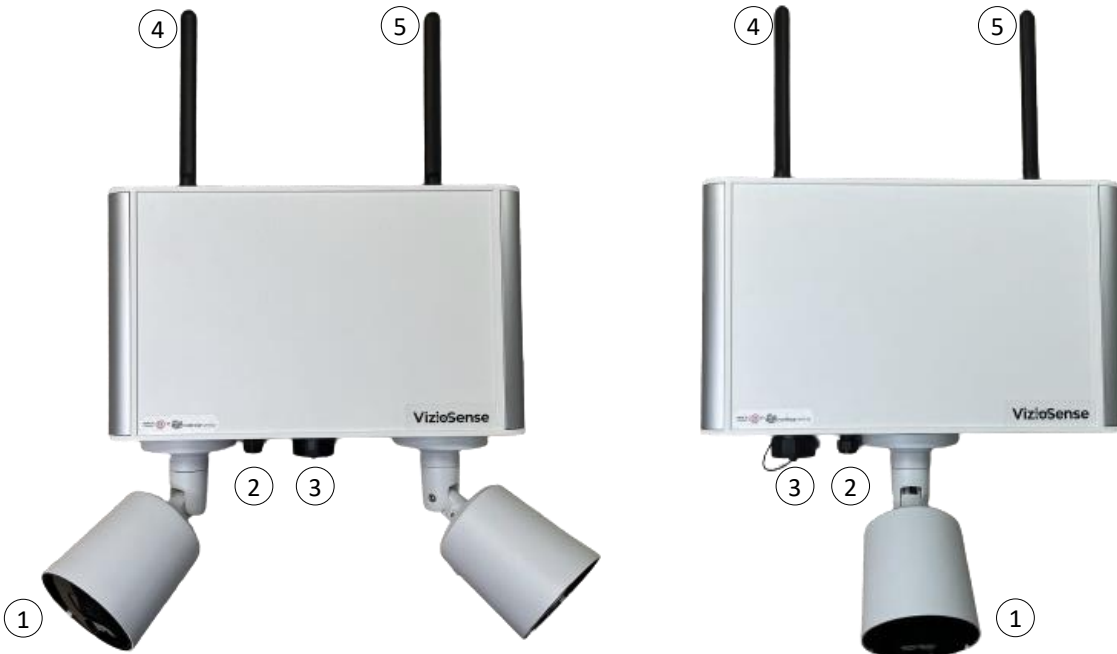

- ① Camera(s)
- ② 8-PIN female circular port for DC12V and relays/optocouplers
- ③ Female RJ45 port for maintenance or PoE+/Ethernet connection
- ④ Wi-Fi & Bluetooth Antenna (optional)
- ⑤ LTE/4G Antenna (optional)

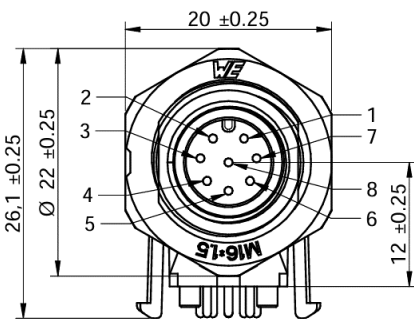

8-PIN Female Circular Port

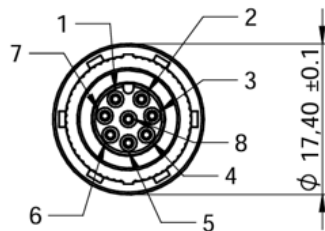

8-PIN Male Circular Connector (as accessory)

- PIN 1: Optocoupler 2
- PIN 2: Optocoupler 1
- PIN 3: Relay 2
- PIN 4: Relay 1
- PIN 5: DC12V Output
- PIN 6: GND
- PIN 7: GND
- PIN 8: DC12V Input

DIMENSIONS

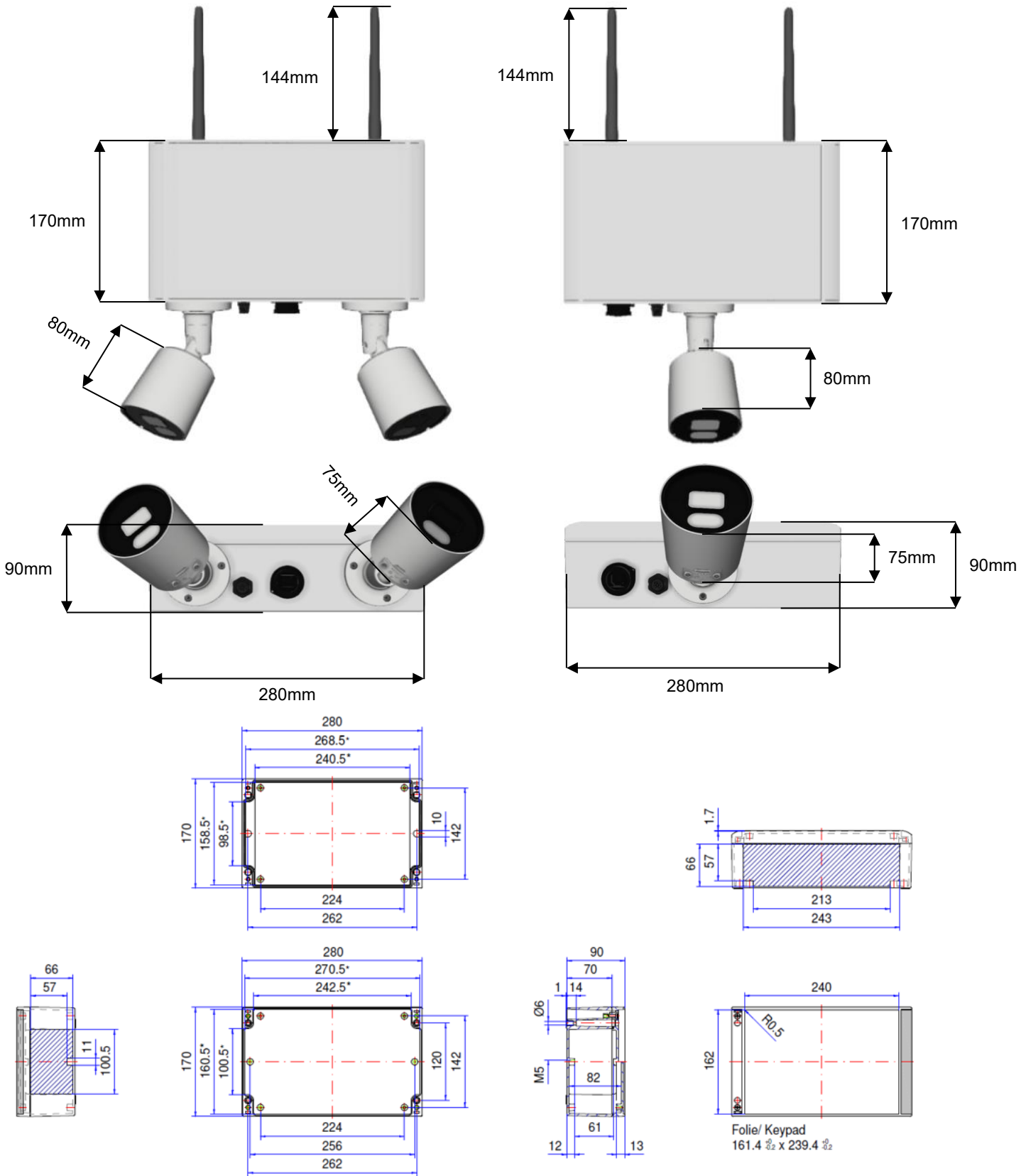

Note: Installation requires 4x 4.5mm or 4mm diameter screws.

ACCESSORIES

Smart Battery

For street light posts having no power supply during day time or other installations without 24-hour continuous power supply



Chemical System	LiFePO4 (lithium iron phosphate)
Typical Capacity	18.0Ah/230.4Wh (21h for the single camera sensor; 18h for the dual camera sensor)
Nominal Voltage (Output)	DC12.8V
External Charge Voltage (Input)	AC230V
Charging time	3.5 to 4h
Life Cycle	2000 charging/discharging cycles
Dimensions	517mm(L)x86.2mm(W)x86.2mm(H)
Weight	Approx. 4250g
Housing Material	Aluminium
Ingress Protection	IP68
Color	Silver gray/Black
Operating Conditions	-20°C to 60°C, less than 90% RH



Pole Mount

To fix the camera sensor on a street light post or other pole

Adjustable Diameter	From 67 mm to 127 mm
Dimensions	272mm(L)x162mm(W)x43mm(H)
Weight	Approx. 965g (without hose clamps)
Material	Stainless steel
Color	White

Voltage Converter

For the situations where the power supply is coming from the AC230V



Max. Power	24W
Output Voltage	DC12V
Input Voltage	AC100-250V 50/60HZ
Dimensions	165mm(L)x30mm(W)x20mm(H)
Weight	Approx. 200g
Ingress Protection	IP67
Operating Conditions	-20°C to 50°C

Non contractual images

INTEGRATOR PLATFORM

The Integrator Platform provides integrators and installation companies the ability to preview, manage and configure devices. An API is available for seamless integration and data transmission.

Site Configuration

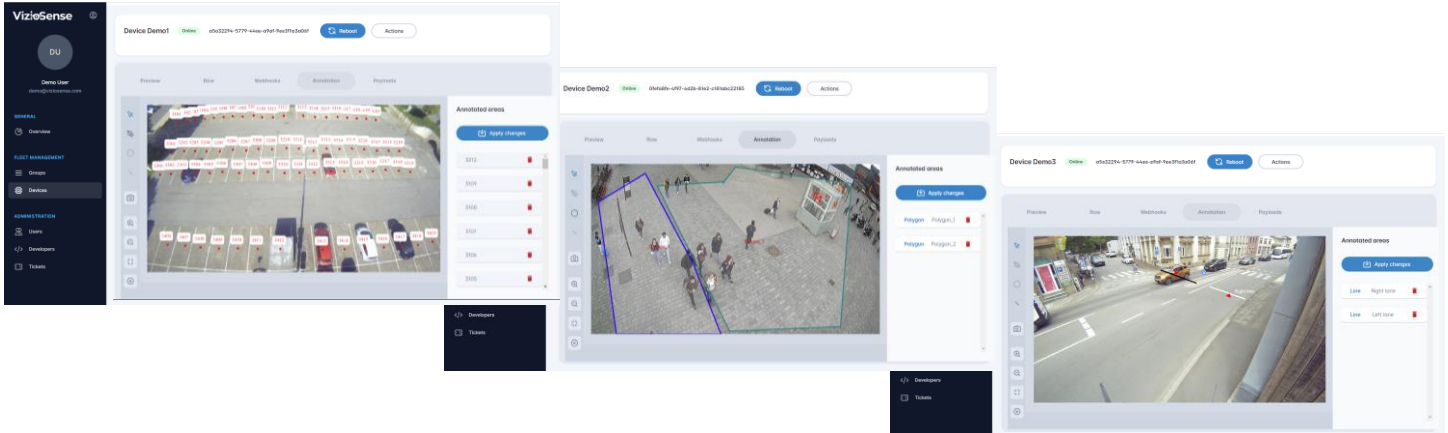

Fleet Management

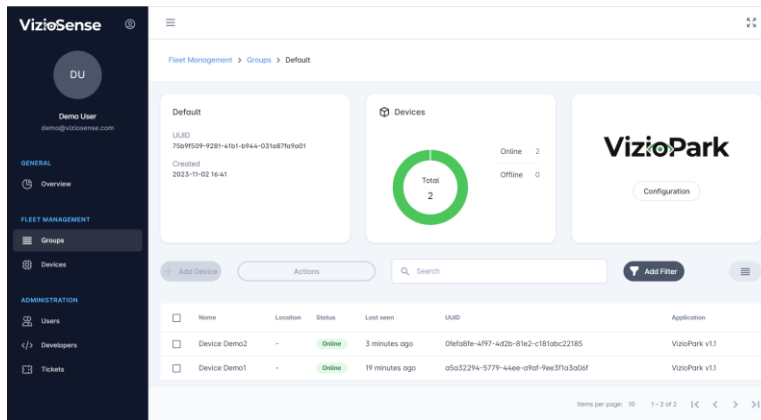

- ✓ Keep Alive messages
- ✓ Firmware Update Over The Air
- ✓ User Rights management

Remote Maintenance

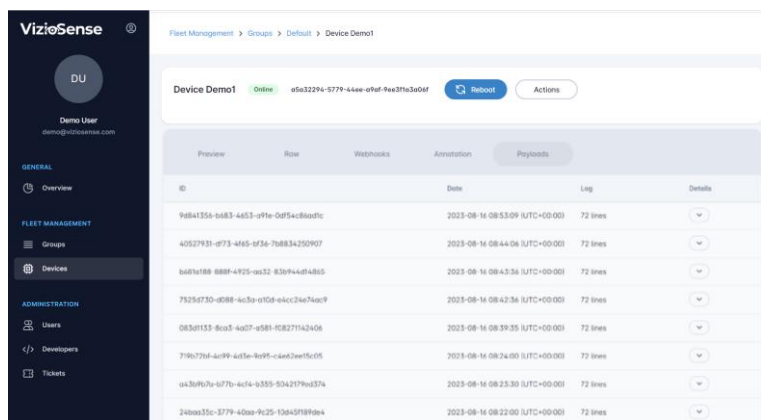

- ✓ Payload history
- ✓ Remote device reboot

APPLICATIONS AND USE CASES

VizioPark

Real-time parking occupancy and stats



Downtown



Park-and-Ride



Shopping Malls



Motorway Rest Areas



Marked Spaces



EV Charging Spots



Delivery / Drop-off zone



PRM Spaces

VizioCount

Real-time counting for people, cars, bicycles, and assets



Queue Management



Urban Planning



Mobility Study



Smart Lighting



Municipalities



Smart Buildings



Retail



Public Transportation

VizioCrowd

Real-time counting for people in dense environments



Railway Stations & Airports



Museums



Stadiums



Concerts & Festivals



Shopping Malls



Major Intersections

MODEL NAMING CONVENTION

NP-1-4G

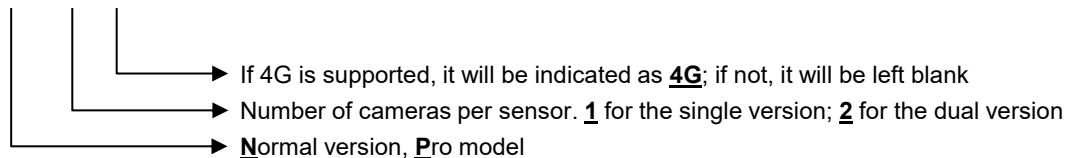

Model	Single	Dual	LTE/4G	PoE+/Ethernet
NP-1	✓		X	✓
NP-2		✓	X	✓
NP-1-4G	✓		✓	✓
NP-2-4G	✓	✓	✓	✓

Contact us

If you have any questions, please email us at:
contact@vizioSense.com